

AUTROL®

DOC. NO.: C2100-E05A



Smart Temperature Transmitter

MODEL

ATT2100 ATT2200



ATT 2100



ATT 2200

Duon System Co.,Ltd.

ATT2100



ATT2200



Description of Product

The AURTOL Smart Temperature Transmitter is a microprocessor-based high performance transmitter, which has flexible sensor input and output, automatic compensation of ambient temperature and process parameters, configuration of various parameters, communication with HART protocol. All Data of Sensor (Tag No., type, range etc.) is to be input, modified and stored in EEPROM.

Function

- » Flexible Sensor input : RTD, T/C, mV, Ohm
- » Various output : 4 ~20mA(Analog), Digital Signals
- » Automatic Compensation by Linearization table in which user can modify the various necessary values
- » Automatic Compensation of Ambient Temperature
- » Setting Various Parameters : Zero/Span, Unit, Fail-mode, Trim, etc.
- » Self Diagnostic Function : Sensor, A/D Converter, Memory, Power, etc.
- » Digital Communication with HART protocol
- » Flameproof Approval and Intrinsic Safety Approval: KOSHA, KTL,ATEX,FM, GOST(ATT 2100)
- » Marine Certificate : ABS, LR, DNV, BV

Functional Block Diagram

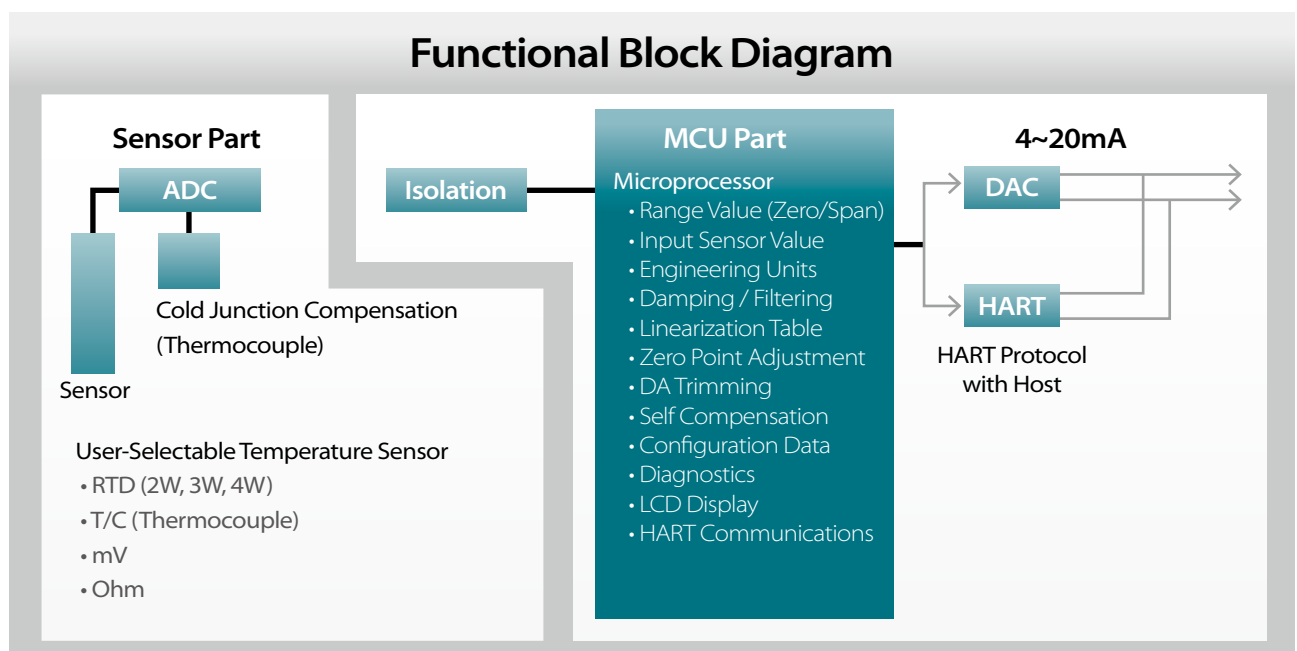

Features

» Superior Performance

- Excellent Accuracy (Refer to Page 4)
- Long-Term Stability (Refer to Page 4)

» Flexibility

- Selection of various T/C, RTD, mV, Ohm
- Data Configuration with HART configurator

» Reliability

- Automatic Compensation : Linearization of sensor input, Ambient temperature compensation
- Continuous Self Diagnostic
- Fail-mode Process function
- EEPROM Write Protection
- I/O Isolation : Grounded Thermocouple
- CE EMC Conformity Standards (EN50081-2,EN50082-2)

Transmitter Description

» Sensor Inputs

The model ATT2100 and ATT2200 are compatible with a variety of temperature sensors, including 2W, 3W and 4Wire RTDs, thermocouples, and other resistance and millivolt inputs

(see Page 6).

The sensor part module converts the temperature sensor into the digital value. The MCU module calculates the process temperature value based on the digital value.

The sensor type and configuration are software-selectable using the Hand-Held terminal and PC configurator.

The sensor modules include the following features

- The software of the transmitter compensates for the thermal effects, improving performance.
- Precise input compensation during operation is achieved with temperature and voltage or resistance correction coefficients that are characterized over the range of temperature sensor and stored in the EEPROM memory.
- Input sensor type
 - RTD (Pt-100 ohm) : 2W, 3W, 4Wire
 - Thermocouple : B, E, J, K, N, R, S, T type
 - mV : -10 ~ 75mV
 - Ohm : 0 ~ 340 Ω

» Basic Setup

AUTROL Temperature Transmitter can be easily configured from any host that support the HART protocol.

Configuration consists of setting the following transmitter operational parameters.

- Sensor Type
- Number of sensor input wires
- 4 and 20mA Points (Zero/Span)
- Engineering Units
- Damping Time
- Tag : 8 alphanumeric characters
- Descriptor : 16 characters
- Message : 32 characters
- Date : day / month / year

» Calibration and Trimming

- Lower/Upper Range (zero/span)
- Sensor Linearization
- Zero Point Adjustment
- DAC Output Trimming
- Self-Compensation

» Self-Diagnosis and Others

- CPU & Analog Module Fault Detection
- Communication Error
- Fail-mode Handling
- LCD Indication (for ATT 2100)

ATT2100 Transmitter Field Wiring and Sensor Wiring Diagrams

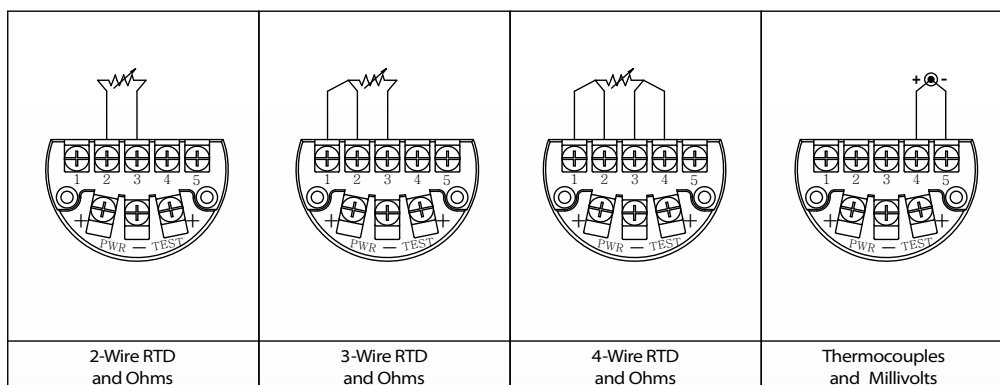

Performance Specifications

» Reference Accuracy

(Refer to Table 1)

» Stability

RTDs.

$\pm 0.12\%$ of Reading or 0.15°C , whichever is greater, for 24 months

Thermocouples

$\pm 0.12\%$ of Reading or 0.15°C , whichever is greater, for 12 months

» Repeatability

$\pm 0.05\%$ of span

» Ambient Temperature Effect

(per 1°C change in ambient temperature.)

Sensor Type	Digital Accuracy	D/A effect
2W, 3W, 4Wire RTD		
Pt 100(a=0.00385)	0.003 $^{\circ}\text{C}$	0.002% of Span
Pt 100(a=0.003916)		
Thermocouple		
NIST Type B	0.046 $^{\circ}\text{C}$	0.002% of Span
NIST Type E, J, K, N	0.005 $^{\circ}\text{C}$ +0.00054% of reading	
NIST Type R, S, T	0.015 $^{\circ}\text{C}$ If reading $\geq 200^{\circ}\text{C}$ 0.021 $^{\circ}\text{C}$ - 0.0032% of reading if not	

» Power Supply Effect

Less than $\pm 0.005\%$ of Span per Volt

» Update Time and Turn-On Time

Update Time : 0.5 seconds

Turn-On Time : 5 seconds

» Failure Mode

The value to which the transmitter drives its output in failure is as follows

Fail High: Current ≥ 21.75 mA

Fail Low: Current ≤ 3.75 mA

Function Specifications

» Range and Sensor Limits

(Refer to Table 1)

» Zero and Span Adjustment Limits

- Zero and span values can be set anywhere within the range limits stated in Table 1.
- Span must be greater than or equal to the minimum span stated in Table 1

» Output (*Analog Current and Digital Data*)

Two wire 4~20mA, Digital process value superimposed on 4~20mA signal, available to any host that conforms to the HART protocol

» Power Supply & Load Requirement

- External power supply required.

* 250 ohm load – 17.5 Vdc

* up to a 550 ohm load – 24 Vdc

Max. Loop Resistance = $(E-12) / 0.022$

(E = Power Supply Voltage)

- Voltage Range : 12 to 45 Vdc
- Voltage Rating : 24 Vdc $\pm 30\%$

» Loop Load

0 to 1500 Ω for Operation

250 to 550 Ω for HART Communications

» Ambient Humidity Limits

5% ~ 100%RH (Relative Humidity)

» Ambient Temperature Limits

- -40°C ~ 85°C (without condensing for ATT2100)
- -20°C ~ 85°C (without condensing for ATT2200)
- -30°C ~ 80°C (with LCD module)

» Storage Temperature

- -40°C ~ 85°C (without condensing)
- -20°C ~ 85°C (without condensing for ATT2200)

» Isolation

Input / output isolated to 500Vrms (707 Vdc)

Physical Specifications

» Electrical connections

1/2-14 NPT conduit with M3.5 Screw Terminals

» Materials of Construction

Electronics Housing : Low-copper aluminum
Flameproof and waterproof (IP67)

Paint : Epoxy-Polyester or Polyurethane

Cover O-ring : Buna-N

Mounting Bracket : 304SST with U-bolt (304SST)
for 2-inch pipe

Nameplate : 304 SST

» Weight

1.2 kg below (Standard-excluding options)

2.6kg (SST Housing-excluding options)

Hazardous Location Certifications (option)

» KOSHA Approvals K1 Code :

* KOSHA: Korea Occupational Safety & Health Agency

Flameproof for Class I, Zone 1 : Ex d IIC T6, IP67

Ambient Temperature : -20 to 60°C

Power Supply : Max. 45 Vdc

Output : 4 to 20 mA + HART, Max. 22 mA

» ATEX Approvals E1 Code :

CE 0344  II 2 G Ex d IIC T6, T5 or T4

Operating Temperature: -20°C ≤ Tamb ≤ +60°C

T6 for process ≤ 85°C; T5 for process ≤ 100°C

T4 for process ≤ 130°C

FM & FM Canada Approvals F1 Code :

* FM: Factory Mutual explosion proof

* FM Canada: Canadian requirements

Explosion proof for Class I, Division 1

Groups A, B, C and D

Dust-ignition proof for Class II, Division 1,

Groups E, F and G

Dust-ignition proof for Class II, Division 1

"T6, see instruction for temperature code if process temperature above 85°C"

Ambient Temperature : -20 to 60°C

Enclosure: indoors and outdoors, NEMA Type 4X

Conduit seal required within 18" for Group A only.

Nonincendive for Class I, Division 2, Groups A, B, C & D;

Class II, Division 2, Groups E, F & G; and Class III, Division 1,

Temperature Code T4

Ambient Temperature : -20 to 60°C

Enclosure: indoors and outdoors, NEMA Type 4X

Supply Voltage : 1.9~42Vdc

ATT2200 Transmitter Field Wiring and Sensor Wiring Diagrams

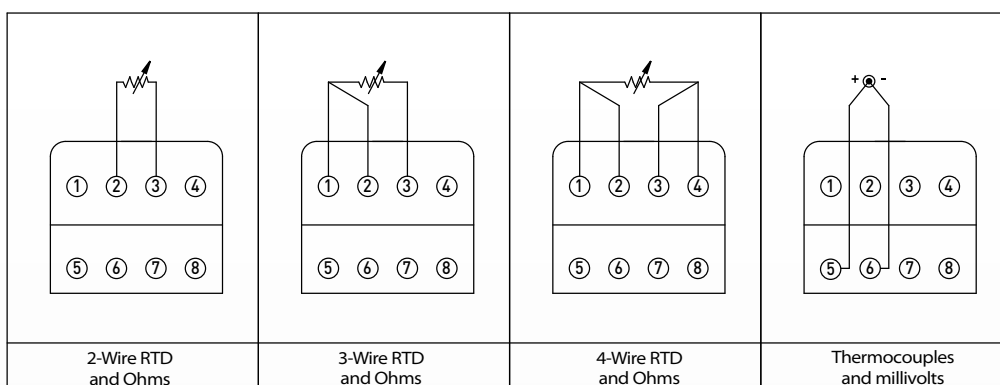

General Specifications

1. Temperature Sensor Range & Accuracy

<Table 1>

Sensor Type	Sensor Reference	Input Range	Minimum Span	Digital Accuracy	D/A Accuracy Of Span
RTD					
Pt-100	KSC 1603-1991 (a=0.00385) DIN	-200 ~ 650°C	15°C	±0.17°C	±0.03%
Pt-100	JISC 1604-1981 (a=0.00391)	-200 ~ 650°C		±0.16°C	
Thermocouple					
NIST Type B	KSC1602-1982	100 ~ 1,820°C	25°C	±0.77°C	±0.03%
NIST Type E		-200 ~ 1,000°C		±0.20°C	
NIST Type J		-200 ~ 1,200°C		±0.25°C	
NIST Type K		-200 ~ 1,350°C		±0.35°C	
NIST Type N		-200 ~ 1,300°C		±0.40°C	
NIST Type R		0 ~ 1,760°C		±0.60°C	
NIST Type S		0 ~ 1,740°C		±0.50°C	
NIST Type T		-200 ~ 400°C		±0.25°C	
Millivolt Input				-10 ~ 75 mV	
Ohm Input		0 ~ 340 Ω	20 Ω	± 0.35 Ω	

- < Note > 1) RTD input : a=0.00385 : KS, JIS, DIN, IEC, a=0.00391 : US.
 2) Thermocouple input : KSC 1602-1982, JISC 1602-1981, ANSI MC96.1-1982
 3) Digital accuracy for Type B is ± 3.0 °C from 100 to 300 °C
 4) Digital accuracy for Type K is ± 0.50 °C from -180 to -90 °C

Ambient Temperature Effects (per 1°C change in Ambient temperature)

	Sensor Type	Digital Accuracy	D/A effect per
RTD 2w, 3w, 4-Wire	Pt 100 (a=0.00385)	0.003°C	0.002% of Span
	Pt 100 (a=0.003916)		
Thermocouple	NIST Type B	0.046°C	
	NIST Type E, J, K, N	0.005°C+0.00054% of reading	
	NIST Type R, S, T	0.015°C If reading 0.021°C - 0.0032% of reading if not	

2. Electrical Specifications

Power Supply	Voltage Range : 12 to 45 Vdc Voltage Rating : 24 Vdc ±30%	Output Signal	4 ~ 20 mA dc / HART
HART Loop Resistance	250 ~ 550 ohm(24 Vdc)	Isolation	500 Vrms (707 Vdc)

3. Performance Specifications

Accuracy	Refer to item No.1	Operating Temp	-40 ~ +85°C
Stability for 2 year	±0.1% of Reading or 0.1°C whichever is greater	LCD Meter Operating Temp	-30 ~ +80°C
Ambient Temp. Effect	±0.05% of Span/10°C	Humidity Limits	5% ~ 100% RH(ATT2100)
Repeatability	±0.05% of Span	Power Supply Effect	±0.005% of Span/V

4. Physical Specifications (for ATT 2100)

Electrical Connections	1/2-14NPT(w/M3.5)	Weight (excluding Option Items)	1.2Kg below (standard) 2.6Kg (SST Housing)
Electronics Housing	Aluminum	2" Pipe Stanchion Type bracket	Angle or Flat Type
O-rings	Buna-N	Housing Class	Waterproof (IP67)

Ordering Information

MODEL NO.	Code	Description	
ATT2100	-S	Single Element	
	-D*	Dual Elements	
Housing Materials and Electrical Connection	1	1/2 - 14 NPT	Epoxy Coated-Aluminum
	2	G1/2 (Adapter)	Epoxy Coated-Aluminum
	X	Special	
Process Connection	1	1/2 - 14 NPT	Epoxy Coated-Aluminum
	2	G1/2 (Adapter)	Epoxy Coated-Aluminum
	X	Special	
Sensor Position	H	Horizontal Type	
	V	Vertical Type	
Sensor Type	A <input type="checkbox"/>	RTD (PT100[Ω]) / <input type="checkbox"/> (with Wires)	
	T <input type="checkbox"/>	Thermocouple / <input type="checkbox"/> (with Type)	
	R	Resistor	
	M	Mili-volt	
Hazardous Locations Certifications	K0	Maker Standard (Waterproof : IP67)	
	K1	KOSHA Flameproof Approval : Ex d IIC T6.	
	K2	KTL Intrinsic Safety Approval : Ex ia IIC T5	
	E1	ATEX Flameproof	
	F1	FM & FM Canada Explosion proof	
*F2	FM & FM Canada Intrinsic safety		
Option	M1	LCD Indicator	LPE Lightening Protector (External)
	BA	Stainless Steel Bracket (Angle type) with SST Bolts	
	BF	Stainless Steel Bracket (Flat type) with SST Bolts	
	ST	Stainless Steel Housing	
	X1	Assembly Option (Element/Well)	

Example : ATT2100-S-K1-1-1-H-A3-M1-BA

Note 1 : "*" before order.

MODEL NO.	Code	Description	
ATT2200	-S	Single Element	
	-D*	Dual Element (Special Order, Request to manufacturer if necessary)	
Housing Materials	1	Plastic	
	X	Special	
Hazardous Locations Certifications	K0	Maker Standard	
Sensor Type	A <input type="checkbox"/>	RTD (PT100[Ω]) / <input type="checkbox"/> (with Wires)	
	T <input type="checkbox"/>	Thermocouple / <input type="checkbox"/> (with Type)	
	R	Resistor	
	M	Mili-volt	
Sensor Fail Mode	D	Downscale	
	U	Upscale	

Ex) : ATT2200-S-1-K0-A3-D

Note : "*" before order.

Connection Diagram of Signal, Power, HHT for Transmitter

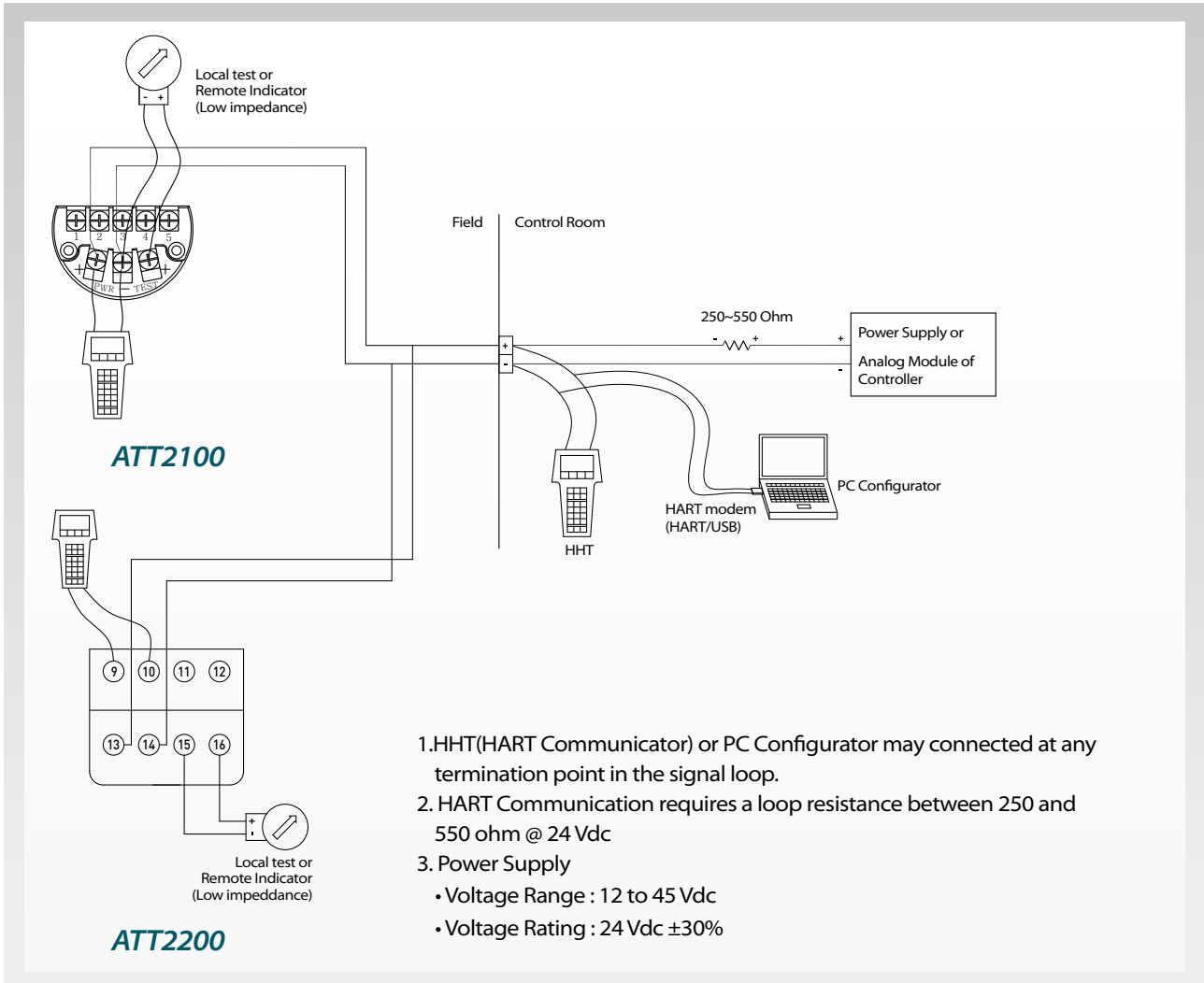

Dimensions of Transmitter (mm)

